

O&G



MATUNUCK LOUNGE

A sumptuous single-piece vented leather cushion stuffed with a feather & down insert. Traditional hand-stretched jute webbing provides the user with perfectly supported soft seating. Designed by Andrew Mau for O&G.

Shown: Charcoal M&G Leather, Ebony Stain on Maple

AVAILABLE IN A RANGE OF UPHOLSTERY OPTIONS
FRAME AVAILABLE IN OUR FULL RANGE OF STAIN FINISHES ON ASH OR MAPLE
OVERALL 32"W • 29.5"D • 30"H • 15" SEAT HEIGHT

WWW.OANDGSTUDIO.COM
401.601.9933

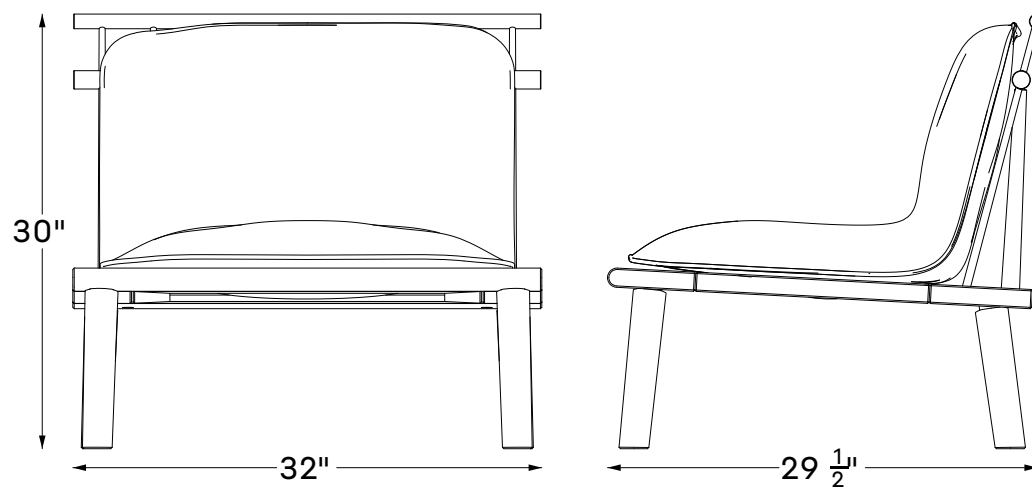

MATUNUCK LOUNGE

FABRIC REQUIREMENTS

SOLID: 4 YDS, 54" WIDTH

PATTERNED: 5+ YDS, 54" WIDTH*

*May require more or less depending on the scale and orientation of the repeat

AVAILABLE IN A RANGE OF UPHOLSTERY OPTIONS
FRAME AVAILABLE IN OUR FULL RANGE OF STAIN FINISHES ON ASH OR MAPLE
OVERALL 32"W • 29.5"D • 30"H • 15" SEAT HEIGHT